



This manual is for reference and historical purposes, all rights reserved.

This page is copyright© by M. Butkus, NJ.

This page may not be sold or distributed without the expressed permission of the producer

I have no connection with any camera company

On-line camera manual library

This is the full text and images from the manual. This may take 3 full minutes for the PDF file to download.

If you find this manual useful, how about a donation of \$3 to: M. Butkus, 29 Lake Ave., High Bridge, NJ 08829-1701 and send your e-mail address so I can thank you. Most other places would charge you \$7.50 for a electronic copy or \$18.00 for a hard to read Xerox copy.

This will allow me to continue to buy new manuals and pay their shipping costs.

It'll make you feel better, won't it?

**If you use Pay Pal or wish to use your credit card,
click on the secure site on my main page.**

HASSELBLAD 203FE

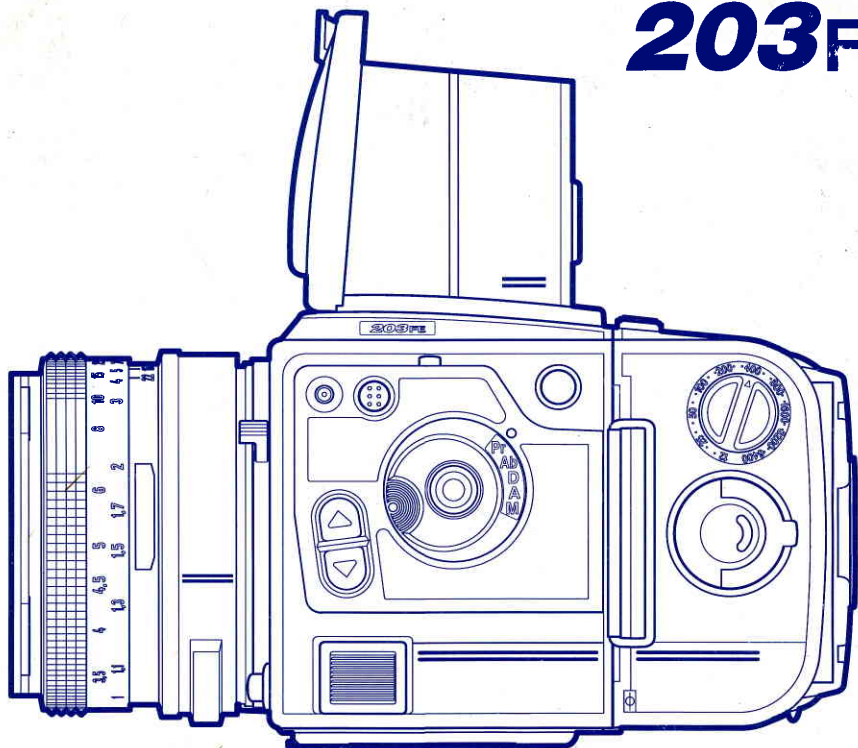

INSTRUCTION MANUAL

Hasselblad 203FE Instruction Manual

Contents

| | | | |
|-----------|--|-----------|--|
| 3 | Hasselblad 203FE Introduction | 21 | Selftimer |
| 4 | Parts and Components | 21 | Grip Cushion |
| 6 | Getting started | 22 | Front |
| 6 | Battery | 22 | Shutter Speed Ring |
| 6 | Cocking the camera | 23 | Exposure Release Button |
| 6 | Front Protective Cover | 23 | Cable Release |
| 6 | Attaching the Lens | 23 | Lens Catch & Shutter Speed Ring Lock |
| 7 | Removing the Lens | 24 | Rear Side and Focal Plane Shutter |
| 8 | Rear Protective Cover | 25 | Bottom Side |
| 8 | Attaching the Magazine | 25 | Top Side |
| 9 | Removing the Magazine | 26 | Viewfinder System |
| 9 | Magazine Status Indicator | 26 | Changing Focusing Hood/Viewfinder |
| 10 | Winding Crank | 26 | Changing Magnifier |
| 10 | Removing the Winding Crank | 27 | Changing Focusing Screen |
| 10 | Attaching the Winding Crank | 28 | Left Hand Side |
| 11 | Strap and Strap Lugs | 28 | Mode Selector |
| 11 | Attaching the Strap | 28 | Automatic Exposure Lock (AE-lock) |
| 11 | Removing the Strap | 29 | Adjustment Buttons |
| 12 | Focusing Hood and Magnifier | 29 | Flash Connectors |
| 12 | Opening the Focusing Hood | 29 | Display Illumination |
| 12 | The Built-in Magnifier | 30 | Lenses |
| 12 | Closing the Focusing Hood | 30 | FE-lenses |
| 13 | Viewfinder Image and Display | 31 | FE-lens Functions |
| 13 | Focusing Screen | 31 | Aperture |
| 13 | Exposure Meter | 31 | Focusing and Depth-of-field |
| 13 | Viewfinder Display | 32 | Depth-of-field Scale |
| 14 | Control Panel | 32 | Depth-of-field Preview |
| 16 | Left Hand Grip | 33 | Infra-red (IR) Photography |
| 16 | Activating Camera & Metering System | 33 | Exposure Value (EV) |
| 17 | Focusing, Exposure, Viewfinder Display | 33 | Other Hasselblad Lenses |
| 18 | Operating Detail Instructions | 34 | E-Magazine Operation |
| 18 | Viewfinder Display & Symbols | 34 | Loading the Magazine |
| 20 | Right Hand Side | 36 | Magazine Load Status |
| 20 | Double Exposure | 36 | Removing the Film |
| 20 | Mirror and Mechanism Pre-release | 36 | Film Tab Holder |
| | | 36 | Film Speed Dial |

37 Magazine Slide Pocket
37 Film Plane Index
38 **203FE Metering System and Operating Modes**
38 The Metering System
39 **Operating Modes**
39 Pr Programming Mode
40 How to use the "Pr" Mode
44 **Ab Automatic Bracketing Mode**
45 How to use the "Ab" Mode
49 **D Differential Mode**
49 How to use the "D" Mode
51 **A Automatic Mode**
52 **M Manual Mode**
52 How to use the "M" Mode
54 **M(ref) Manual Mode, reference**
54 How to use the "M(ref)" Mode
56 **M(L.E.) Manual Mode, Long Exposure**
57 How to use the "M(L.E.)" Mode
58 **Warning Functions**
58 Permanent Warnings
59 Optional Warning
59 **Flash Photography**
59 **Dedicated Flash Units**
60 How to use the Dedicated Flash
60 Flash set at TTL Mode
64 Flash set at Automatic Mode
67 Flash set at Manual Mode
70 **Non-Dedicated Flash Units**
71 How to use a Non-dedicated Flash
71 **203FE with other Hasselblad Lenses**
72 F-lenses
72 How to use the 203FE with an F-lens
73 **Flash Photography with F-lens**
74 **Accessories**
74 Accessory Mounts
74 Major FE Accessories

76 **Hasselblad System Chart**
78 **Trouble-shooting**
81 **Technical Specifications**
83 **Camera Body Dimensions**
84 **Camera Care, Service and Guarantee**
85 **APPENDIX A**
85 **Hasselblad 203FE with CF- and C-lenses**
85 **CF-lenses**
85 CF-lens Design and Function
86 F-setting
87 **How to use the CF-lens**
88 **Flash photography with CF-lens**
89 Lens in F Mode
89 Dedicated and Non-dedicated Flash Units
89 Lens in C Mode
89 Dedicated Flash Units
91 Non-dedicated Flash Units
92 **C-lenses**
92 How to Use the C-lens
93 **Flash Photography with C-lens**

Service and Maintenance

The Hasselblad products are exceptionally reliable and durable, but continuous and extensive professional use will require maintenance and overhaul at regular intervals at an authorized Hasselblad Service Center. Turn to page 82 and read about maintenance and service!

Warranty

Provided you purchased the equipment from an authorized Hasselblad dealer or distributor it is covered by an international warranty for one year from the date of delivery. Read more about the warranty on page 82!

HASSELBLAD 203FE – Speed and precision

Your Hasselblad 203FE is a camera designed for professionals who often work on location under unpredictable light conditions and fast-moving subjects. With the 203FE you have a choice of either aperture priority automatic or truly manual function. In the automatic modes you can manually adjust the computer-controlled exposure within the range +5 to -5 EV. The extremely accurate focal plane shutter provides the widest range of shutter speeds in the medium format field: 34 minutes to ultra fast 1/2000 s with 1/2 stop increments in manual mode or 90 s to 1/2000 s with 1/12 stop increments in automatic mode. It also provides the fastest flash synch speed among medium format focal plane shutters: 1/90 s.

Primarily designed to take advantage of this remarkable shutter are the Hasselblad FE (former TCC) series lenses, ranging from the medium wide-angle 50mm f/2.8 to the short telephoto 350mm f/4, including the powerful Planar 110mm f/2. And using the Hasselblad Converter 2XE in one stroke doubles the range of focal lengths!

These outstanding lenses by Carl Zeiss are supported by the brightest possible viewfinder image, provided by the Acute-Matte focusing screen, completed with the illuminated LCD display with all relevant exposure and setup data.

The metering system compiles the information from the lens, the built-in exceptionally sensitive light meter, and the film speed setting on the attached E or TCC magazine to calculate the accurate shutter speed. If any of the parameters, e.g. the pre-set aperture, is changed the shutter speed changes accordingly.

Attaching the Hasselblad Winder motorizes your 203FE for the full use of the automatic bracketing function with a frame rate of 1.3 fps and your own choice of 1/3-, 2/3- or 1-step bracketing interval. Press the exposure button and hold for the number of frames you decide – the camera automatically adjusts the shutter speed according to your choice.

Above all, according to the Hasselblad philosophy, your 203FE can use the full range of Hasselblad CF lenses with built-in shutters for the added advantage of battery-independent shutter operation and a wider range of shorter flash sync speeds and focal lengths.

This instruction manual describes in detail how to operate your Hasselblad 203FE. Read it carefully to avoid mistakes and to get full access to the Hasselblad potential. Exploiting that potential is limited by your own imagination only!

203FE, Parts and Components

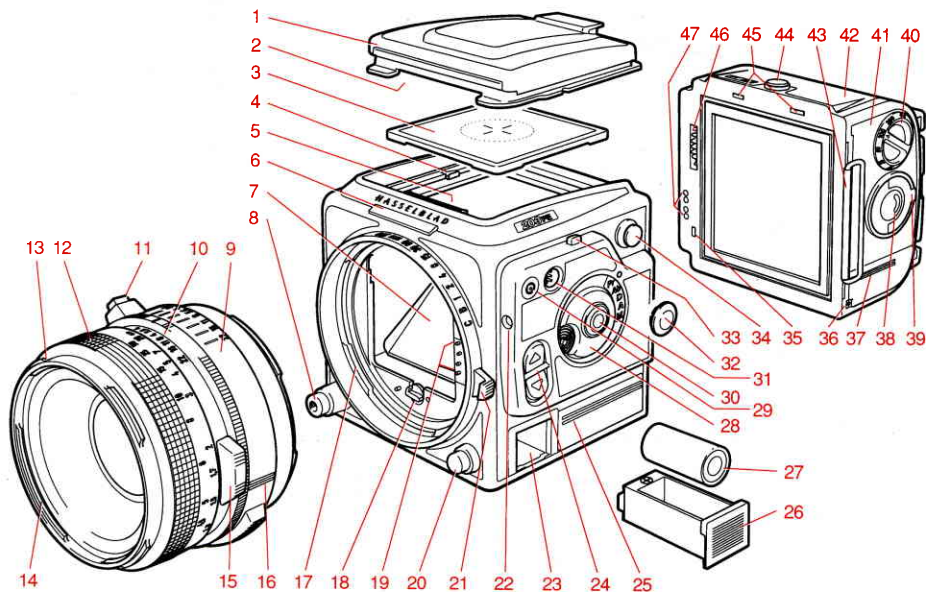

- | | | |
|---------------------------------|--|--------------------------------|
| 1 Focusing hood cover | 17 Lens mount | 33 Display illumination button |
| 2 Display recess | 18 Drive shaft | 34 Strap lug |
| 3 Acute-Matte* focusing screen | 19 Data bus connection bracket | 35 Indicator trigger slot |
| 4 Focusing screen catch | 20 Lens catch /Shutter speed ring lock | 36 Film plane indicator |
| 5 Liquid crystal display (LCD) | 21 Shutter speed ring | 37 System mark |
| 6 Display illumination window | 22 Selftimer indicator | 38 Film load indicator |
| 7 Viewfinder mirror | 23 Battery compartment | 39 Film holder key |
| 8 Shutter release button | 24 Adjustment button | 40 Film speed dial |
| 9 Aperture ring with scale | 25 Grip cushion | 41 Film holder |
| 10 Depth-of-field scale | 26 Battery cassette | 42 Film magazine |
| 11 Interlock button (not on FE) | 27 Battery | 43 Magazine slide |
| 12 Focusing ring | 28 Mode selector dial | 44 Film magazine catch |
| 13 Lens front bayonet, exterior | 29 PC socket | 45 Magazine hook slot |
| 14 Lens front bayonet, interior | 30 Automatic exposure lock, AE-lock | 46 Magazine gear |
| 15 Depth-of-field preview knob | 31 Dedicated flash connector | 47 System connectors |
| 16 System mark | 32 Flash connector socket cover | |

*Acute-Matte designed by MINOLTA

203FE, Parts and Components

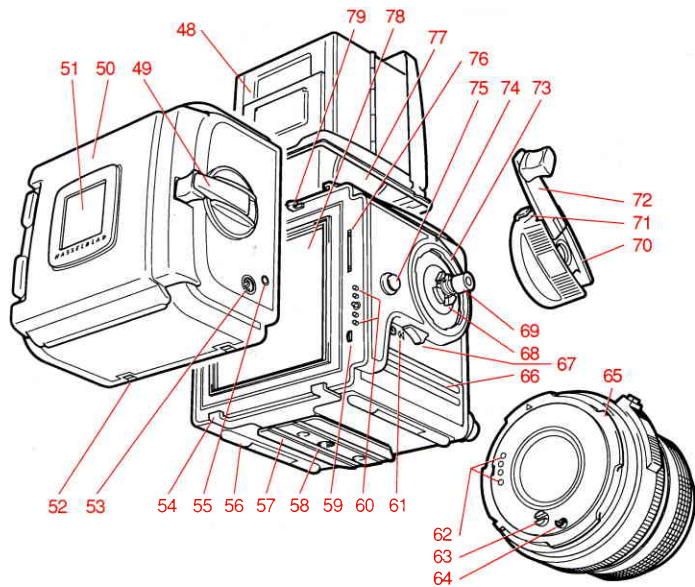

- | | | |
|------------------------------|--------------------------------------|---------------------------|
| 48 Focusing hood | 58 Tripod thread 1/4" | 68 Winder coupling |
| 49 Film winding crank | 59 Magazine indicator trigger | 69 Double exposure button |
| 50 Magazine slide pocket | 60 Data bus connectors | 70 Crank hub |
| 51 Film tab holder | 61 Selftimer indication | 71 Winding crank catch |
| 52 Magazine support slot | 62 Lens data bus connectors | 72 Winding crank |
| 53 Frame counter | 63 Lens drive shaft | 73 Winder bayonet mount |
| 54 Magazine support | 64 Lens drive shaft catch | 74 Winding crank index |
| 55 Magazine status indicator | 65 Lens bayonet plate | 75 Strap lug |
| 56 Camera support | 66 Grip cushion | 76 Magazine driving gear |
| 57 Quick coupling slide | 67 Mirror release / selftimer button | 77 Magnifier |
| | | 78 Shutter curtain |
| | | 79 Magazine hooks |

NOTE: In the text the positions of components are described in relation to the camera as you see it when taking a photograph, i.e. the lens is on the front, the viewfinder is on the top, the winding crank is on the right hand side, and the control panel is on the left hand side.

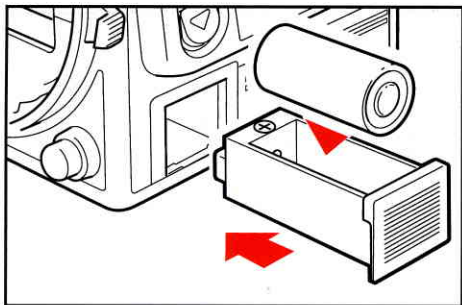

Getting Started

This section describes how you prepare your Hasselblad 203FE for use. You will find comprehensive information how to operate the camera in the section starting on page 18. Follow the instructions step by step to avoid jamming or damaging the camera. Always keep the rear protective cover on to protect the shutter curtain when the magazine is detached!

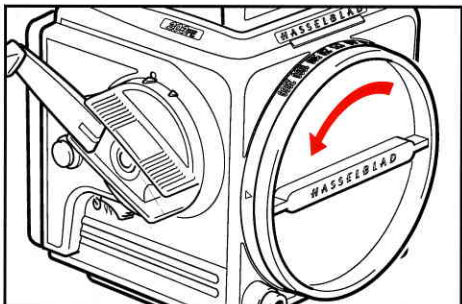

Battery

The battery compartment and cassette is located in the lower forward corner on the left hand side of the camera body. Pull out the cassette and install the battery - 6V type PX28L or equivalent - according to the marking on the cassette. Push the cassette all the way back into the compartment.

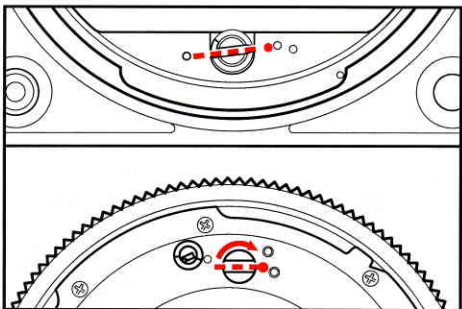

Cocking the Camera

Cock the camera after installing the battery. Fold out the winding crank on the right hand side, press the button in the center of the crank and rotate it clockwise one turn until it locks (Cf. page 20, 'Double exposure').

Front Protective Cover

the front protective cover is attached to the lens bayonet mount. Rotate it counter-clockwise and lift it out of the mount.

Attaching the Lens

Remove the lens' rear protective cover by rotating it counter-clockwise and lifting it off the lens.

Check that both the camera and the lens are cocked. The lower illustration on page 6 shows the proper position against the index marks for the camera drive shaft (top) and the lens drive shaft (bottom). If the lens is not cocked you can insert a coin or a similar object in the slot and turn the shaft in the direction of the arrow approx. 4/5 of a full turn. You will find that holding the camera body in your left hand and the lens in your right hand as shown in the illustration (top, right) is the easiest way to attach the lens.

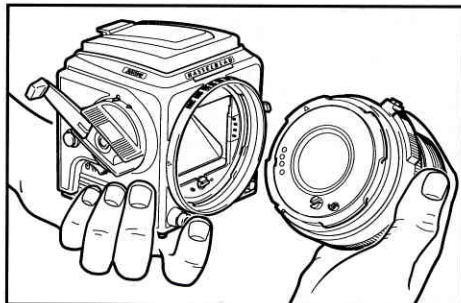

When you have aligned the red index on the lens with that on the camera body as shown in the illustration, the lens will fit easily into the bayonet mount. You can then rotate it clockwise until it stops with a faint click as the lens locks in place.

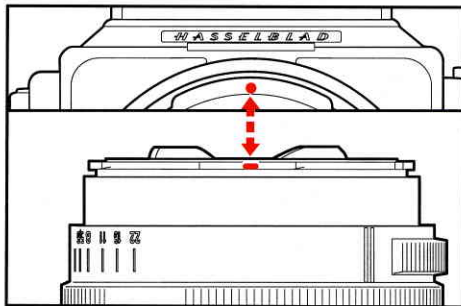

Removing the Lens

Depress the lens catch button, rotate the lens counter-clockwise and lift it out of the bayonet mount.

NOTE: You can only attach and remove the lens when the camera is cocked (fully wound) and not in pre-released mode (see page 20).

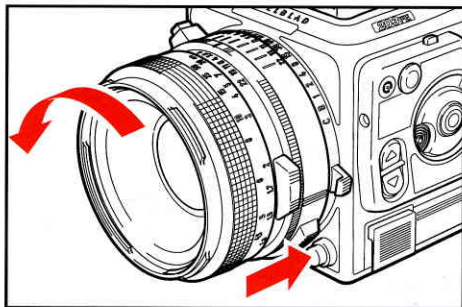

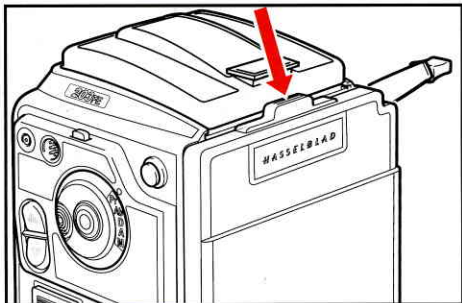

Rear Protective Cover

Depress the catch, tilt the cover backwards and lift it off.

Always keep the rear protective cover on to protect the shutter curtain when the magazine is detached!

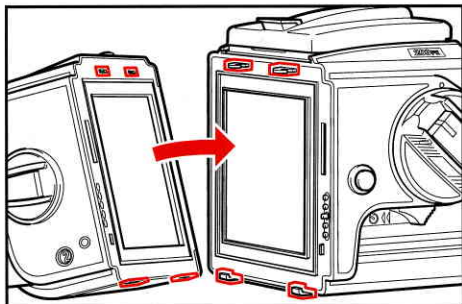

Attaching the Magazine

Ensure that the magazine slide is fully inserted and that the magazine status indicator is white. If the indicator is red, then follow the instructions on page 9. Rest the magazine on the magazine supports with the support lugs properly engaging the recesses in the magazine bottom. Carefully swing the magazine towards the camera body, checking that the magazine hooks fit into the slots in the magazine. Push the magazine gently but firmly against the hooks while sliding the magazine catch to the right.

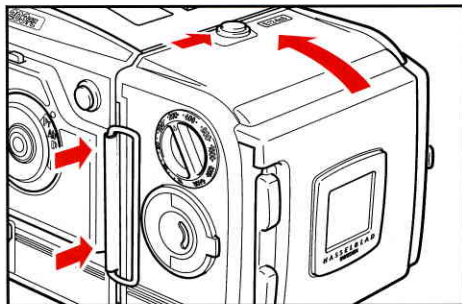

Release the button when the magazine makes contact with the camera body and then push the button to the left to ensure that it has reached the locked position. Remove the slide to positively lock the magazine to the camera body.

Removing the Magazine

It is advisable to have the camera fully wound and the magazine status indicator showing white. If the indicator shows red, then follow the instructions below.

Insert the magazine slide fully and with the hinge towards the front of the camera.

Slide the magazine catch to the right, tilt the magazine back and lift it off the supports.

NOTE: The magazine cannot be removed without inserting the magazine slide. The slide protects the film from fogging. Note also that the camera cannot be operated when a magazine with the slide inserted is attached to the camera.

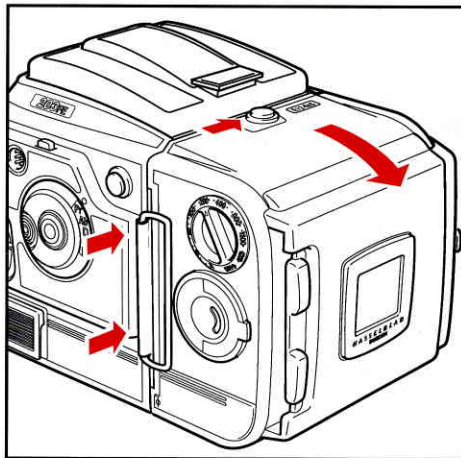

The Magazine Status Indicator

The status indicator on the right hand side of the magazine shows whether the magazine is ready to operate (white) or not (red), i.e. the film has not been advanced. Do not attach a magazine showing white to a camera that is not re-cocked! Wind it first, otherwise you will lose one frame. Do not attach a magazine showing red to a fully wound camera! That could result in an unintentional double exposure since the frame in position in the magazine probably already is exposed.

If the status indicator shows red, release the camera (page 17) before attaching the magazine. Then, when you wind the camera, the film will be advanced one frame.

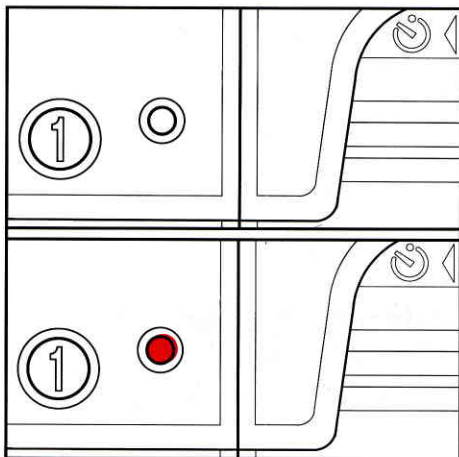

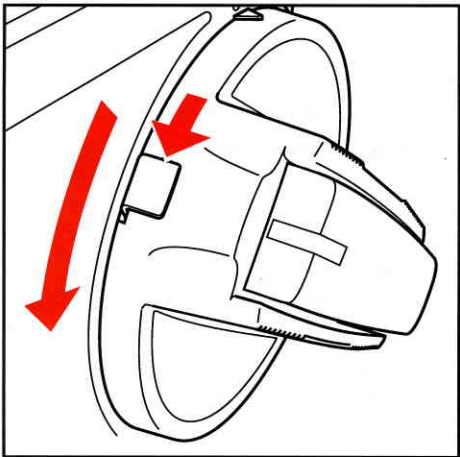

The Winding Crank

One full revolution of the winding crank winds the camera, cocks the lens mechanism and transports the film to the next frame.

Underneath the crank are the drive shaft and the bayonet mount for the Hasselblad Winder (pages 74, 76), which can be attached after removing the crank. It is recommended that the camera is fully wound when the crank is removed or replaced.

Removing the Winding Crank

To remove the crank push the catch lever on the rear of the crank hub downwards while rotating the crank counter-clockwise. Then pull it straight out from the shaft.

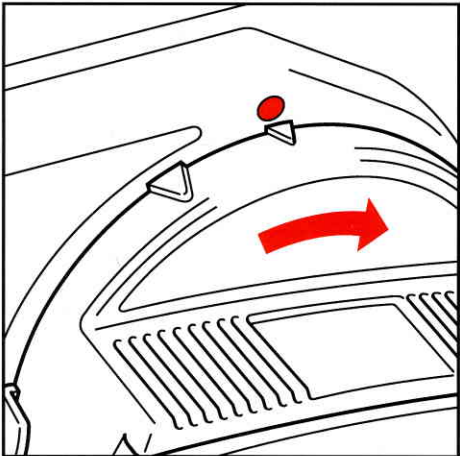

Attaching the Winding Crank

On the side of the crank hub are two triangular index marks, a larger one and a smaller one. Attach the crank to the shaft with the smaller mark aligned with the red dot, located immediately above the mount. While pushing the crank against the camera body, rotate it clockwise until the larger mark is aligned with the red dot.

Strap and Strap Lugs

The 203FE is delivered with a medium wide shoulder strap, packed separately. You will find other types of straps in the Hasselblad Product Catalog. All straps are provided with special clips for easy attaching and removing of the strap.

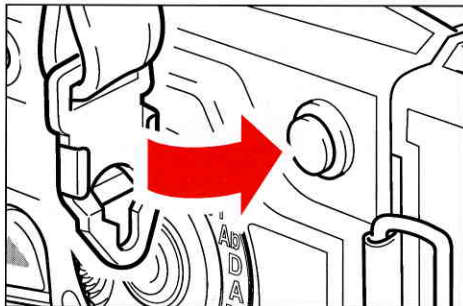

Attaching the Strap

Place the main body of the strap clip from behind over the strap lug on the camera with the strap pointing backwards (see fig.). Press the tip of the clip towards the camera while pulling the strap to slide the clip over the lug to the locked position.

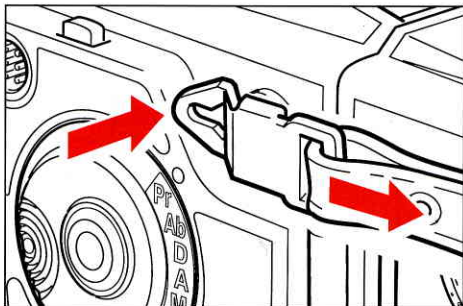

Removing the strap

Hold the strap pointing backwards and lift the locking plate of the clip high enough to pass over the top of the lug. Push the clip forwards to slide it off the lug.

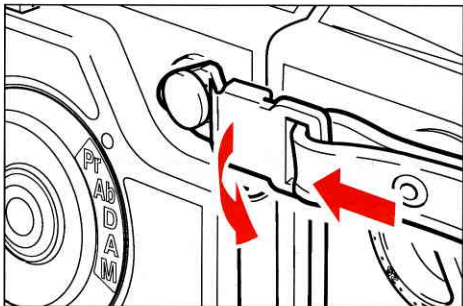

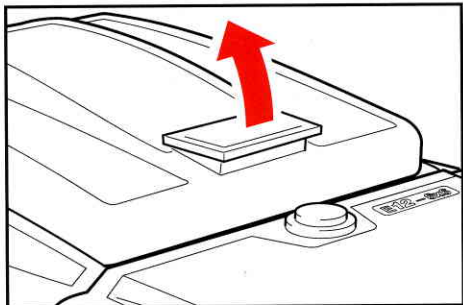

Focusing Hood and Magnifier

Opening the Focusing Hood

Lift the lid with a firm grip on the tab at its rear edge and swing it up to a vertical position. The hood unfolds automatically and locks in open position.

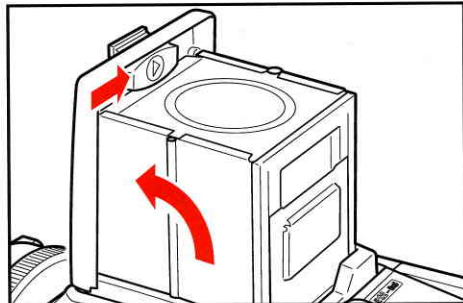

The Built-in Magnifier

Use the built-in 4x magnifier to enlarge the viewfinder image, e.g. for more accurate focusing. To unfold it, push the oval catch inside the lid to the right, as indicated in the illustration.

To fold the magnifier down, simply push it back towards the lid until it locks.

The magnifier can easily be exchanged for one with a suitable correction lens to match your individual eyesight (see page 26).

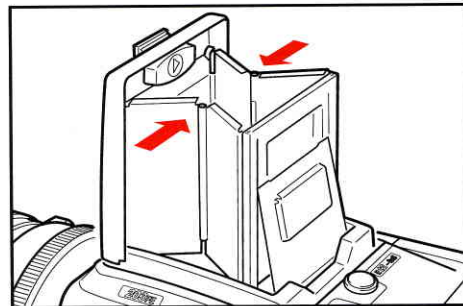

Closing the Focusing Hood

"Pinch" the side plates at the hinge points and fold the hood back down.

Viewfinder Image and Display

Focusing Screen

The Hasselblad 203FE is equipped with the Acute-Matte focusing screen featuring the highest brightness and resolution among the Hasselblad focusing screens. The center of the screen is indicated by a hairline cross. A circle of dots indicate the metering area used by the built-in selective meter.

See page 27 how to change the focusing screen.

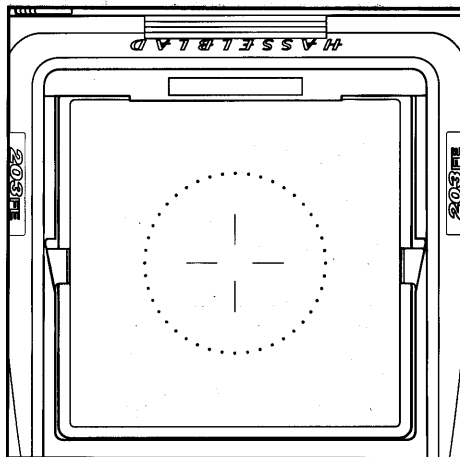

The Exposure Meter

The exposure meter is a center weighted selective meter where the metered value derives from a approx. circular $\varnothing 28$ mm central area corresponding to 20% of the total image area. The metering range for a film speed of ISO 100/21° extends from EV 0.5 to EV 21.5 at f/2,8.

The Viewfinder Display

Located above the upper edge of the viewfinder image is the display, which is the information center of the camera. You find a comprehensive description of the display and its symbols on pages 18-19.

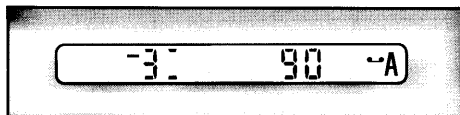

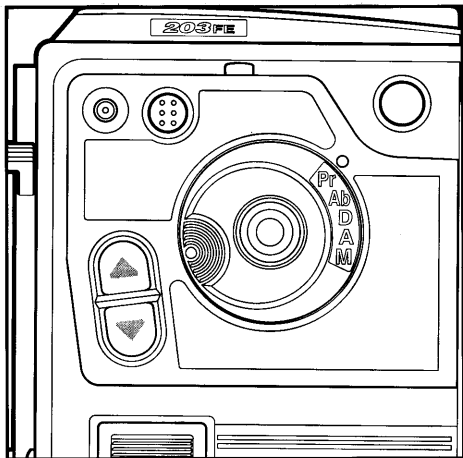

The Control Panel

The control panel occupies most of the left hand side of the camera body. It includes all the controls for the various functions of the 203FE, such as:

- The Flash Connectors
- The Display Illumination Switch
- The Mode Selector Dial
- The Adjustment Buttons

Flash Connectors

The flash connectors are located underneath the protective cover in the upper forward corner of the control panel. The smaller one is a standard PC-socket and the larger one is a 6-pin connector for TTL-controlled dedicated flash units.

The PC-socket

Non-dedicated flash units and certain adapters should be connected to this socket.

The Dedicated Flash Connector

A dedicated flash unit connected to this 6-pin outlet directly or through a suitable adapter will be fully controlled by the camera processor.

You find detailed information on flash photography on pages 59-71.

The Display Illumination

Pressing the button above the flash connectors turns the display illumination on or off. The switch has a toggle function. It works only when the camera is activated.

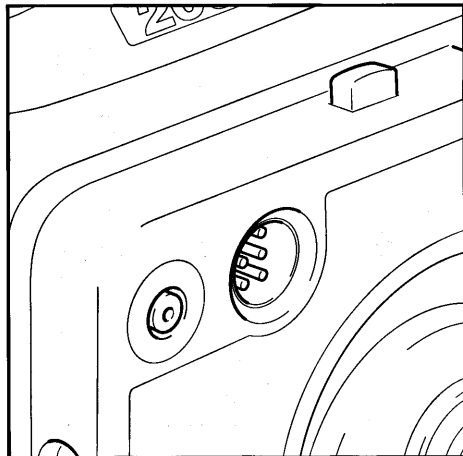

The Mode Selector Dial

With the mode selector dial you can select any of the five operating modes **Pr**, **Ab**, **D**, **A** or **M** available in the 203FE. The Ab, D, A and M modes are used for photography and Pr for the programming of certain functions.

The Automatic Exposure (AE) Lock

In the center of the mode selector dial is a push-button, marked with a red circle. It operates the AE-lock and certain other functions, depending on the setting of the mode selector dial. You can also use it to start the electronic operating system in the camera.

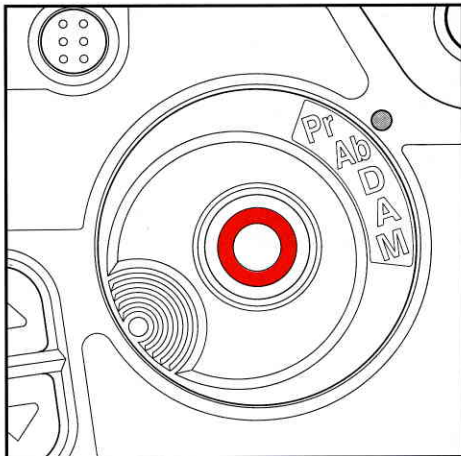

The Adjustment Buttons

These keys also have multiple functions depending on the setting of the mode selector dial.

The functions of the mode selector dial, the AE-lock and the adjustment buttons are described in detail on the pages 28-29.

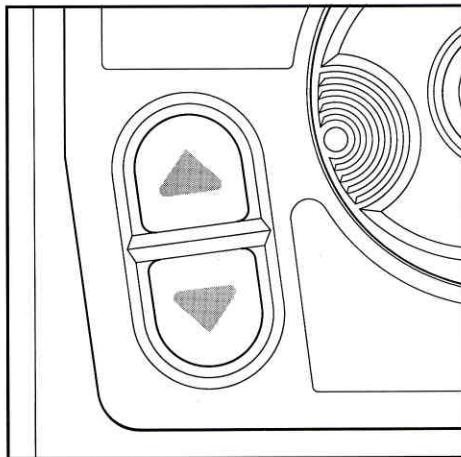

Left Hand Grip

Holding the 203FE in your left hand with your index finger on the release button, as shown in the upper illustration below, is the most convenient grip. You can reach the AE-lock and the adjustment keys with your left thumb (lower illustration below) and your right hand is free for focusing, aperture setting, operating the crank or changing the lens or the magazine.

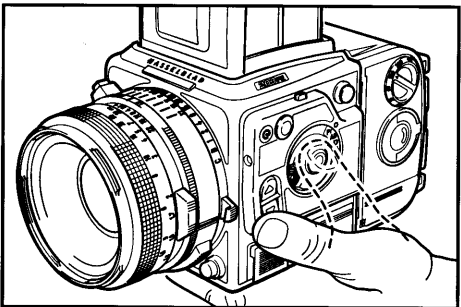
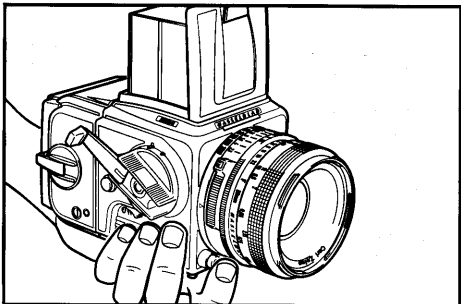

Activating the camera and the metering system

Before you operate the 203FE you have to wind the camera to cock the shutter (if it is released) and switch on the metering system. To be able to release it you also have to remove the magazine slide.

The fully wound 203FE can be switched on in two different ways:

1. By depressing the exposure button half-way in, i.e. to the "pressure point".
2. By depressing the AE-lock button.

Activation as per 1. above can only be performed when the magazine slide is removed. At normal light levels this activation occurs when the exposure button is depressed for an exposure.

At low light levels the camera should always be activated well before releasing the exposure in the automatic modes (Ab, D and A).

Activation as per 2. is not possible if the AE-lock has been kept depressed for more than 16 seconds.

Keep the magazine slide inserted when you wish to avoid unwanted battery power consumption caused by unintentional activation of the metering system.

The electronic system and the viewfinder display turn off automatically 16 seconds after the last key or button operation, but all relevant data are stored in the memory.

Focusing, Exposure Release and Viewfinder Display

Turn the focusing ring (page 31) until the image of the subject appears sharp in the viewfinder.

Depress the exposure button to the pressure point (half-way in).

If the mode selector dial is set in **Ab**, **D** or **A** position the display now shows – besides a few other symbols described in the following section of this manual the preselected aperture and the shutter speed calculated by the camera computer. With the mode selector set at **M** the display shows the letter M, the pre-selected aperture and the shutter speed set on the shutter speed ring. If the exposure button is released again, the display instead shows the selected shutter speed and the difference in EV between the metered and the manually set values.

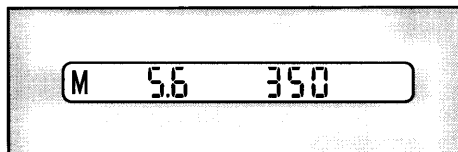
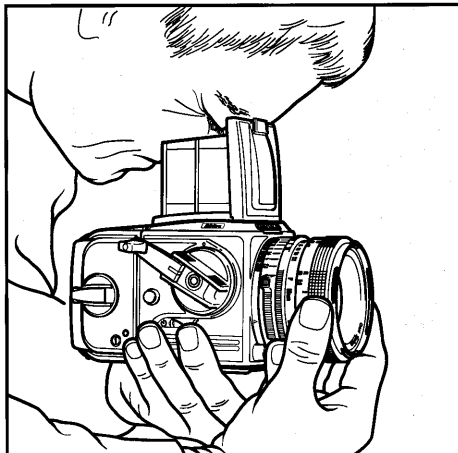

You can now press the exposure button all the way in to make the exposure. After releasing the button you can rotate the winding crank one full turn until it locks, to rewind the camera and advance the film one frame.

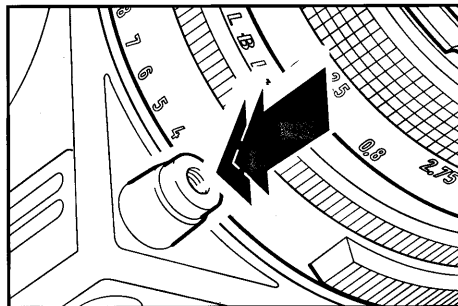

Operating details



Viewfinder Display & Symbols

The display is shown in the illustrations the way it is built into the camera body. When you use a prism viewfinder the display appears reversed, but the microprocessor adjusts all the indications to make them fully readable.



Flash Ready Signal

The flash symbol is illuminated green when a dedicated flash is connected, turned on and ready to be fired (pages 56, 82).



Manual Mode

The mode selector dial is set at **M** (page 52).



Selftimer Function

Flashes when the selftimer is activated. Appears also by programming the selftimer delay in **Pr** mode (page 39).



Differential Mode

The mode selector dial is set at **D** (page 49).



Plus / Minus Sign

Appears together with a correction or deviation value when the mode selector dial is set at **Ab**, **D**, **A**, or **M** and in certain **Pr** functions. The r.h. plus/minus sign can also be displayed together with the "Flash ready signal".



Figures

Eight 7-segment figures indicate corrections, deviations, EV, shutter speed, aperture and certain other information in operation modes **Ab**, **D**, **A** and **M** as well as programming functions in **Pr** mode and certain warnings in various modes of operation.



Fraction Indication

One or two dashes to the right of the figure indicate 1/3 and 2/3 step higher value than indicated by the figure.



Minutes Indication

A vertical dash to the right of the figure indicates that the preceding figure shows the number of minutes at shutter speeds of 60 s or slower.



Film Speed

Indicates film speed set on E- (or TCC-) magazine dial or inserted manually in **Pr** mode (pages 40, 41). **S** in **ISO** is also used to indicate **seconds** at very slow shutter speeds (0,7 s to 60 s) or long exposures (1'30 s to 34').



Battery Check

Appears when battery capacity is low (page 58).



Magazine Check

Indicates that the attached magazine is not a E- (or TCC-) magazine.



Automatic Mode

Indicates that the mode selector dial is set at **Ab** (page 44) or **A** (page 51).



Warning Symbol

Flashes red together with one or more of the other symbols to indicate various problems (pages 58, 59).

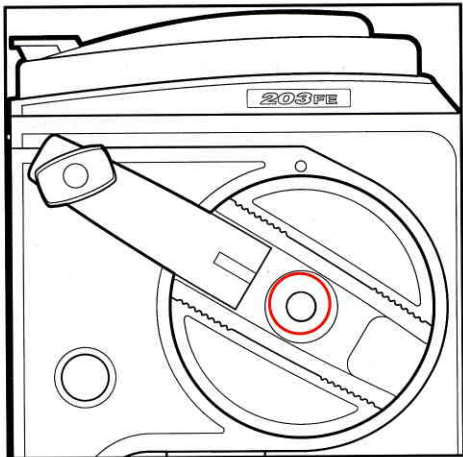

The Right Hand Side

On the right hand side of the camera body are the winding crank, described on page 10, and the pre-release and selftimer lever.

Double Exposure

You can make double (or multiple) exposures by rewinding the camera without advancing the film. This is possible by depressing the double exposure button in the center of the crank hub and simultaneously turning the crank slightly clock-wise. Then you can release the button and complete the winding until the crank locks.

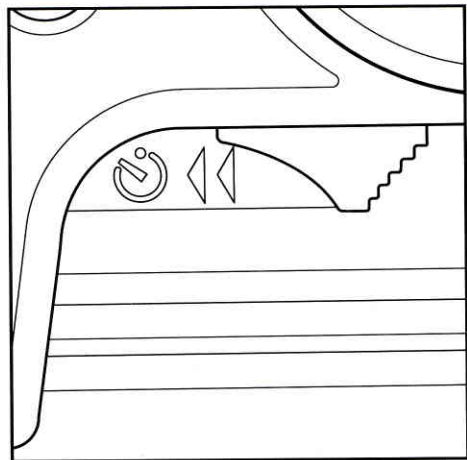

Mirror and Mechanism Pre-release

By pre-releasing certain camera functions and lifting up the mirror you can avoid camera vibrations, reduce the sound level and shorten the time delay between the depressing of the exposure button and the very exposure release. Pre-releasing is done by actuating the pre-release lever **once**. To reset the mechanism and lower the mirror again you perform the operation for a double exposure as described above.

Since the mirror is lifted the light metering is interrupted and locked on the latest recorded value.

The Selftimer

Pressing the pre-release lever a **second** time starts the selftimer function. This is indicated by the selftimer symbol in the viewfinder display and by a flashing red light on the camera body to the left of the lens mount. The standard delay in the selftimer is 10 s but it can be set in intervals between 2 s and 60 s in the **Pr** mode (pages 39,42). At the beginning of the delay the light flashes twice per second, but when two seconds remain of the delay time it increases to four times per second and changes to a continuous light during the last half second. You can interrupt the selftimer function at any time by pressing the pre-release lever again or by a "blind" rewind as for double exposure.

The selftimer function is inoperative when the shutter speed ring is set in positions **B** or **C** (pages 22, 23).

The Grip Cushion

A rubber cushion along the lower edge of the right hand side provides a safe and comfortable grip.

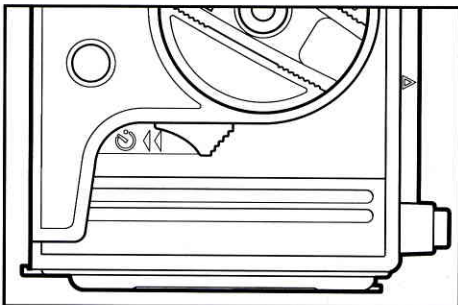
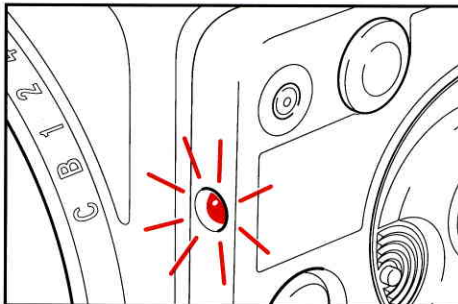
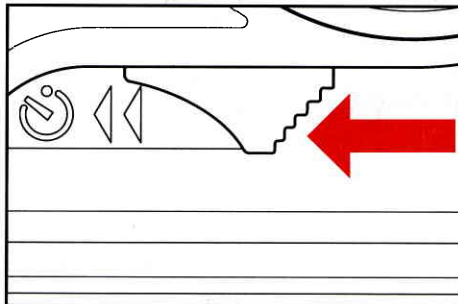

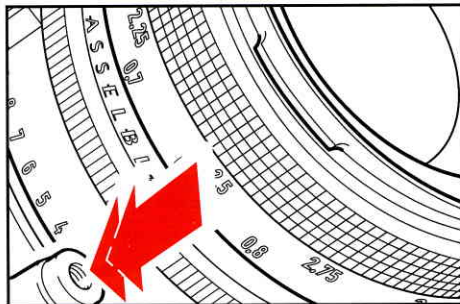
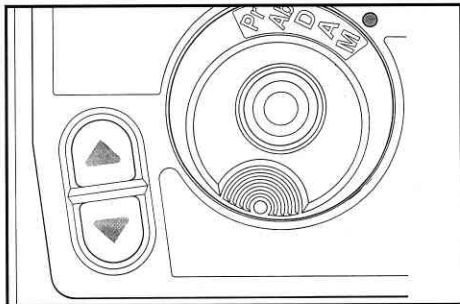
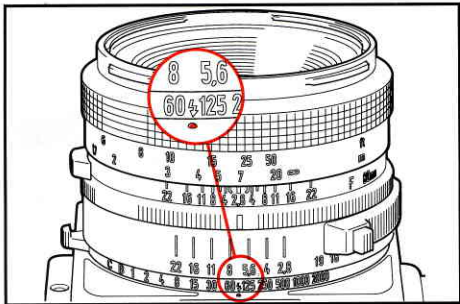

The Front

The Shutter Speed Ring

The shutter speed ring for the focal plane shutter in the 203FE has speed markings from 1 s to 1/2000 s as well as B and C. Between the markings are intermediate half speed click stop settings. One of these settings – 1/90 s, marked with a flash symbol – is the fastest shutter speed for flash synchronisation with the focal plane shutter (page 60). In all modes of operation except **M** the camera processor automatically calculates and sets the shutter speed within the range 90 s to 1/2000 s, irrespective of the shutter speed ring setting.

Long Exposure:

If you require a shutter speed slower than 90 s you have to switch to **M** mode and depress both correction buttons (page 29). This “inverts” the meaning of the split-second markings on the shutter speed ring. i.e. 30 means 32 s etc. until 2000, meaning 2048 s (34 min.). The “inversion” remains as long as the camera is active and 4 sec. after auto-shut-off, or until you change mode or depress both correction buttons a second time.

In the **B** setting in all modes the display continuously shows the elapse exposure time in full seconds up to 60 minutes. The setting marked **C** is used together with CF and C lenses only (Appendix A, page 85).

NOTE: When the mode selector dial is set at **M** (page 52) the display indicates the accurate shutter speed for the intermediate settings.

Exposure Release Button

In the lower right hand corner of the front, within comfortable reach with the left hand grip, is the exposure release button. The button has four different functions:

- A. When depressed to the “pressure point”:
 1. Activate the camera.
 2. Change the display to indicate aperture and shutter speed.
 3. Lock the light value in **Ab** and **A** mode.
- B. When depressed all the way in:
 4. Release the shutter to make the exposure with preset or calculated values.

The exposure button is locked when the magazine slide is in the magazine.

Cable Release

When using shutter speeds slower than 1/30 s you are recommended to put the camera on a tripod and use a cable release, screwed into the threaded mount in the center of the exposure release button. The cable release and the exposure button have identical functions.

Lens Catch & Shutter Speed Ring Lock

The lens catch button is located in the lower left hand of the camera front. To release and remove the lens you have to keep the button depressed while rotating the lens clockwise as seen from behind. The button also operates the lock for the shutter speed ring settings **B** and **C**. Keep it depressed when moving the ring **to** either of these settings. Moving **from** B to 1 is free.

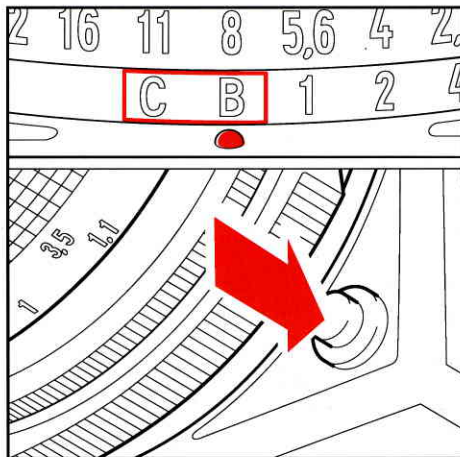
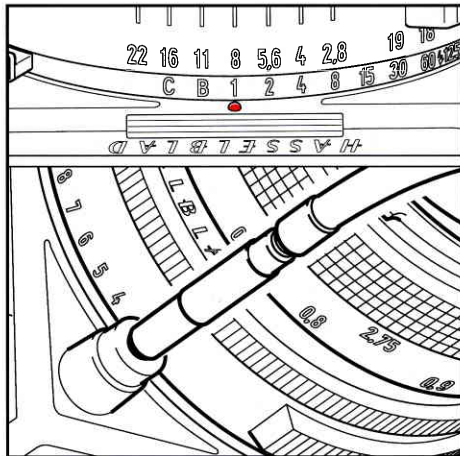

The Rear of the Camera and the Focal Plane Shutter

Avoid leaving the rear of the camera and the shutter curtains unprotected! Always attach the rear protective cover when the magazine is removed!

The opening in the rear of the camera is normally covered by the shutter curtain. The 203FE has a mechanically powered, electronically controlled focal plane shutter with two textile curtains running from left to right across the opening. The running time for the curtains is 1/90 s. In all modes except Manual Mode (pages 39-51) the shutter speeds are calculated by the metering system which controls the shutter. The shutter speeds are adjusted in increments of 1/12 EV-step in the

interval from 1/2000 s to 16 s and 1/4 EV-step in the interval from 16 1/4 s to 90 s, but for practical reasons only the shutter speed for each 1/2 EV-step is indicated in the viewfinder display.

Caution: Whether the shutter is cocked or released, one shutter curtain is always exposed in the opening. When the rear of the camera is not covered by a magazine or a protective cover care should be taken when handling the camera. **Avoid touching the curtain! It is sensitive to damage!**

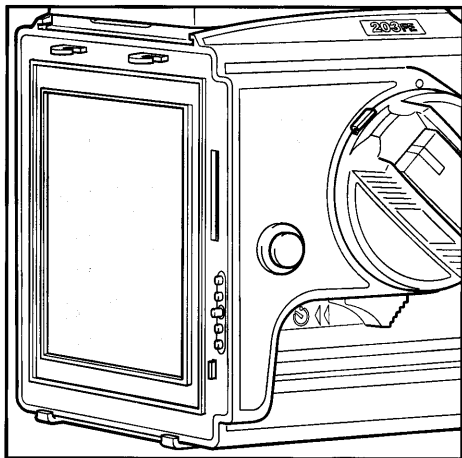

To the right of the opening are the magazine driving gear and the trigger for the magazine status indicator (page 9). There are also the contact pins for the data bus connection between the magazine and the central processor in the camera body. The contact pins are sensitive to contamination and should not be touched.

At the lower edge of the back are the magazine supports and close to the top are the magazine hooks – both together serving to positively fix the magazine to the camera body (page 8).

The Bottom

At the bottom of the camera are the quick coupling plate, the tripod thread and two ridges, supporting the camera when placed on a flat surface. The quick coupling plate fits the Hasselblad accessories, such as the tripod quick coupling and the flash bracket. The tripod thread is 1/4".

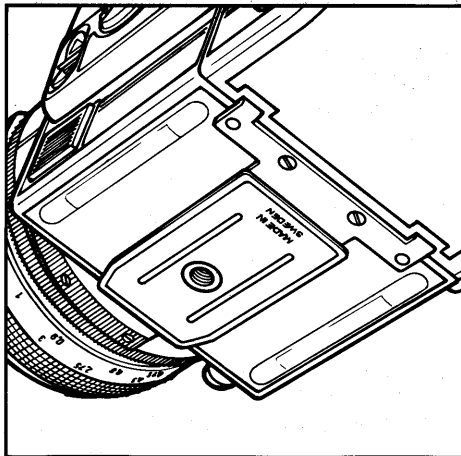

The Top

The viewing components (page 26) occupy most of the camera top. The camera body is supplied with the collapsible focusing hood, which also serves as a protective cover for the focusing screen.

In front of the HASSELBLAD sign is a window for daylight illumination of the viewfinder display screen.

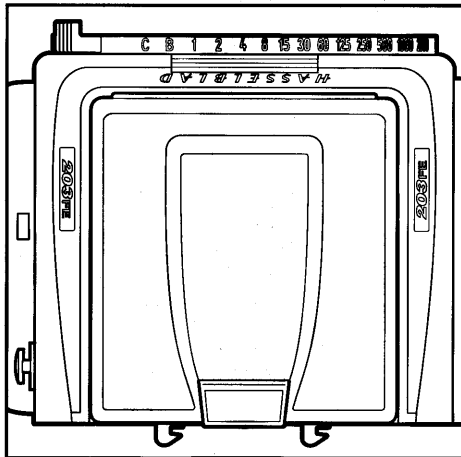

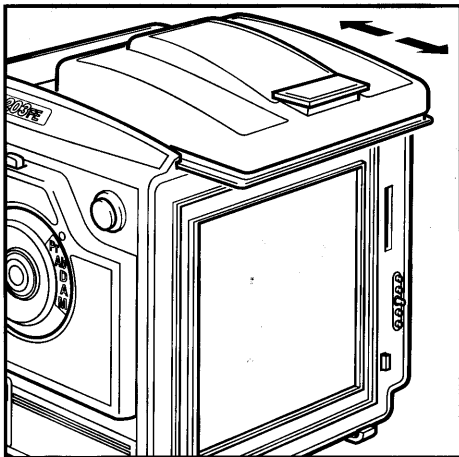

The Viewfinder System

Changing the Focusing Hood or Viewfinder

To remove the focusing hood for using any other viewfinder within the TCC system detach the magazine (or the protective cover). Also fold down the focusing hood to avoid damaging it.

Remove the hood by sliding it to the rear in its guide slots. Slide the replacement viewfinder into the slots and push it forward until it stops. When fully inserted the viewfinder is retained in position by a spring-loaded ball latch until you have reattached the magazine or the protective cover.

Changing the Magnifier

The standard 4x magnifier lens plate can be changed for a plate with a correction lens to compensate for individual eyesight. The supplied magnifier marked -1 provides a comfortable viewing of the focusing screen and the display for most users. Correction lenses, however, are available with powers ranging from $+3$ to -4 diopters.

Change the magnifier as follows:

1. Remove the focusing hood from the camera body and open it by lifting the lid.
2. Release the magnifier by pushing the catch to the left. Push the magnifier halfway down and pull out the lens plate.
3. Keep the plate holder halfway down and insert the replacement lens plate with the printed side up. Fold the hood and put it back on the camera.

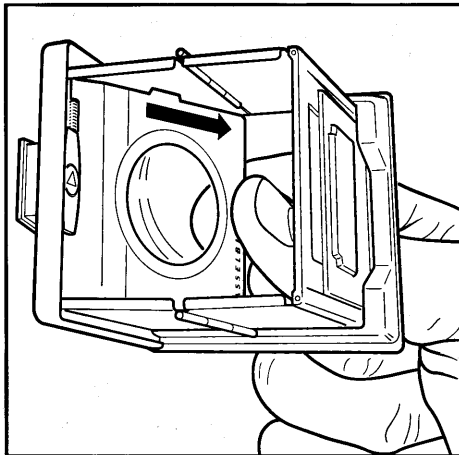

Changing the Focusing Screen

Your 203FE is equipped with the exceptionally bright and sharp Acute-Matte focusing screen. The area inside the dotted circle indicates the area metered by the built-in exposure meter (page 38).

If you wish to replace the focusing screen with any of the other focusing screens in the Hasselblad System, simply follow the procedure below:

1. Detach the magazine and the viewfinder.
2. Push the two screen latches to the side into their recesses.
3. Place your hand over the screen and invert the camera. The screen will now drop into your hand.
4. Insert the replacement screen with the smooth side up and the sharp-edged corners down. Ensure that all four corners of the screen are positively seated on their supports. You need not return the screen latches. This is done automatically when the viewfinder is replaced.

NOTE: Should the screen refuse to drop out by itself, ensure that the camera is fully wound, remove the lens and check that the mirror is in the down position. Put a finger through the lens mount and push gently at the screen from underneath, preferably with a soft cloth between the finger and the screen.

Always avoid direct light into the viewfinder eyepiece when making an exposure.

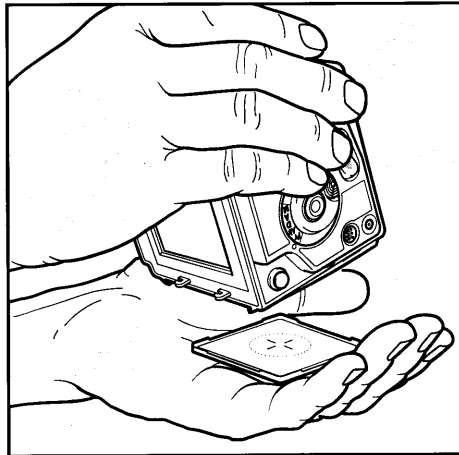
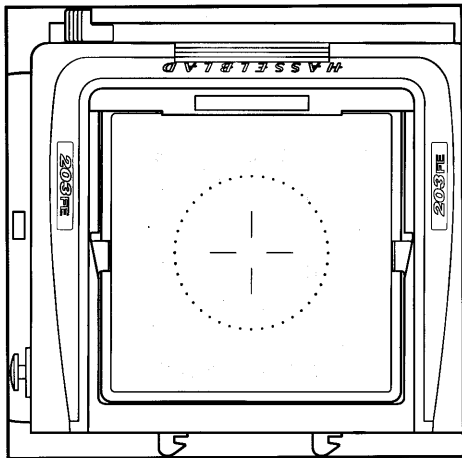

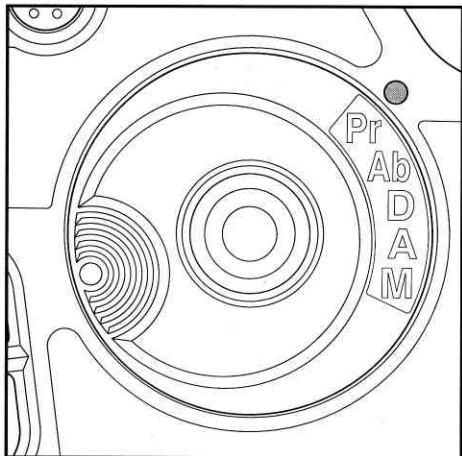

The Left Hand Side

The Mode Selector Dial

The mode selector dial is in the center of the control panel at the left hand side. To select any of the operating modes of the 203FE simply turn the dial until the symbol for that particular mode is aligned with the red index mark. The different operating modes are:

- Pr:** Programming Mode
- Ab:** Automatic Bracketing Mode
- D:** Differential Mode
- A:** Automatic Mode
- M:** Manual Mode

The functions of these modes are described in detail on pages 38-53.

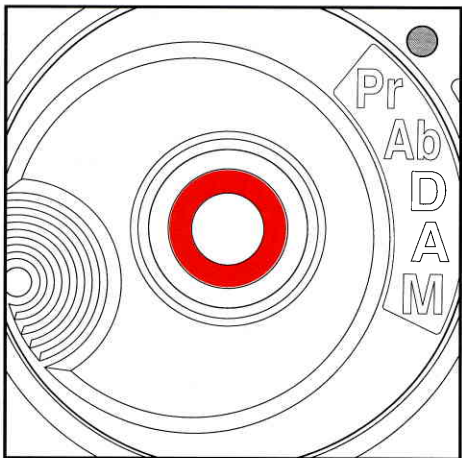

The Automatic Exposure (AE) Lock

The AE-lock is the push-button in the center of the mode selector dial, marked with a red ring. It has different functions, depending on the modes of operation as described later. It can also be used to activate the camera's metering system (page 16) except after the AE-lock has been depressed for more than 16 seconds, e.g. if the camera has been laying on the left hand side. In that case the camera can only be activated for normal use by depressing the exposure release button to the pressure point.

The Adjustment Buttons

The adjustment buttons also have different functions depending on the selected mode. With a few exceptions a single push on the upper button increases and on the lower button decreases the value to be adjusted. If you keep the button depressed for more than half a second the value starts to change at a rate of 4 – 5 steps per second until the button is released.

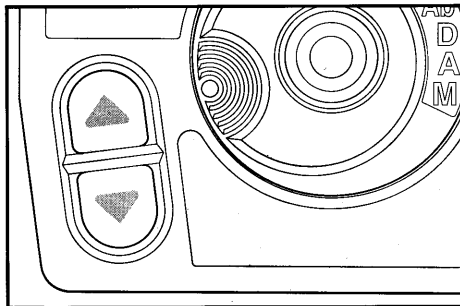

The Flash Connectors

The larger six-pin TTL-connector provides automatic control of dedicated flash units. The Hasselblad Proflash 4504 can be connected directly to the 203FE but other dedicated flash units may require a suitable adapter, such as the Hasselblad SCA-adapter 390 or 590, between the unit and the camera. The smaller connector is a common PC-socket for any kind of flash unit. You can find further instructions on flash photography with the 203FE on pages 59 and 88.

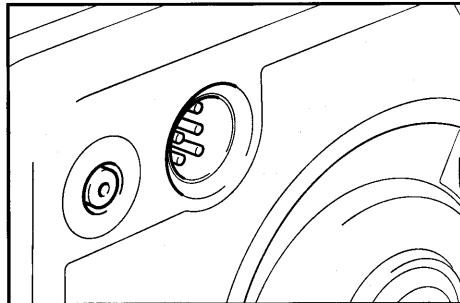

Display Illumination

In low light levels depressing the switch button on the upper edge of the control panel switches on the illumination of the viewfinder display. The button has a toggle function.

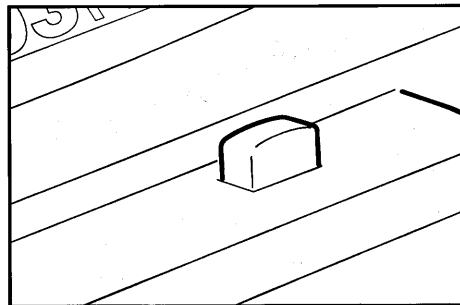

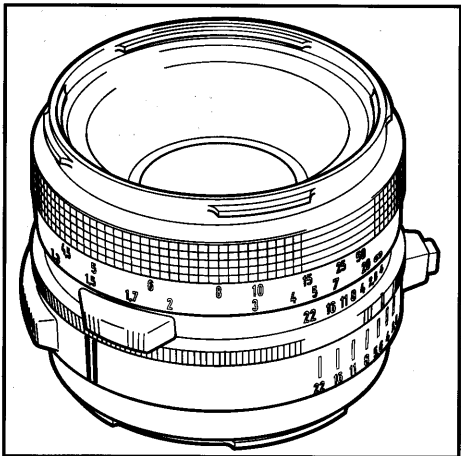

Lenses

The Hasselblad lenses made since 1957 can be separated in two major groups, each with two sub-groups:

1. Lenses with a built-in leaf shutter:
 - C lenses
 - CF lenses
2. Lenses without shutter:
 - F lenses
 - FE lenses

All these lenses can be used on the 203FE, but only the FE lenses will give you access to the full range of exclusive and sophisticated features of the 203FE.

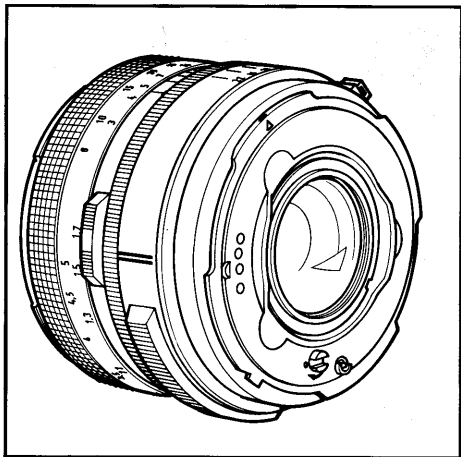

FE Lenses

The Hasselblad FE lenses, which have no built-in shutter, can easily be identified by their system sign, i.e. the blue twin lines on the left hand side of the aperture ring. Another sign, visible only when the lens is detached from the camera body, are the four data-bus contact pins in the bayonet plate at the rear of the lens. They are used for the data transmission between the lens electronics and the electronic system in the camera body. The contact surfaces of these pins are sensitive to contamination and should not be touched with your fingers. Attach the protective cover after removing the lens from the camera and never set the lens down on the unprotected bayonet plate!

FE Lens Functions

Setting the Aperture

The aperture ring is the one closest to the shutter speed ring on the camera body. Use it to pre-set the selected f-stop. The full f-stops marked on the ring have click stops, but there are also click stops for each intermediate half f-stop. The set aperture value can be read against the heavy index line on the grooved ring in front of the aperture ring. It will also show on the viewfinder display when you depress the exposure button halfway in, i.e. to the pressure point.

The aperture ring has two grooved grips for handling convenience. One of these grips has a push-button which has no function on the 203FE.

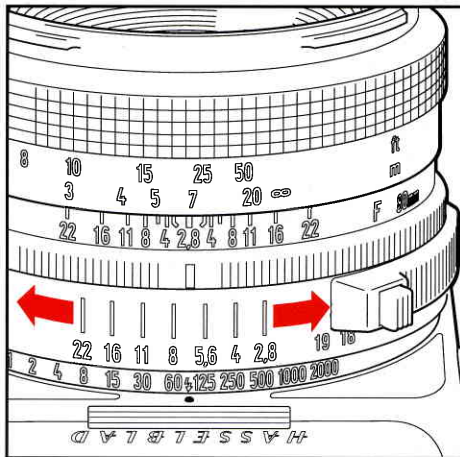

Focusing and Depth-of-field

The focusing ring is the rotating ring with a knurled rubber grip closest to the front of the lens. It has two scales for the focusing distance, the white meter scale and the orange inch/foot scale. Rotate the focusing ring until the image of your subject appears absolutely sharp on the focusing screen.

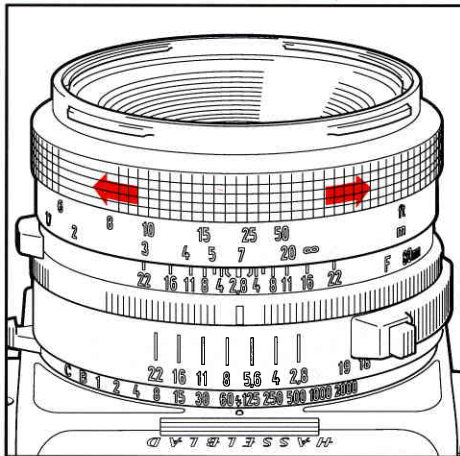

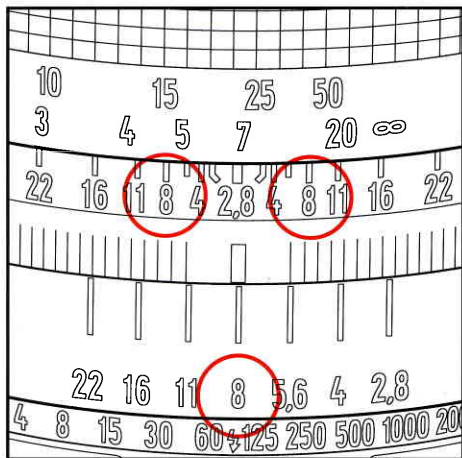

The Depth-of-field Scale

The depth-of-field scale repeats the aperture values on both sides of the heavier index line between the fixed ring with the index line and the focusing ring. When the image is focused on the screen you can read the focusing distance opposite the index line in the depth-of-field scale. The depth-of-field limits can be read opposite the left and right values corresponding to the pre-set aperture value. The illustration depicts the depth-of-field for the pre-set aperture value of 8.

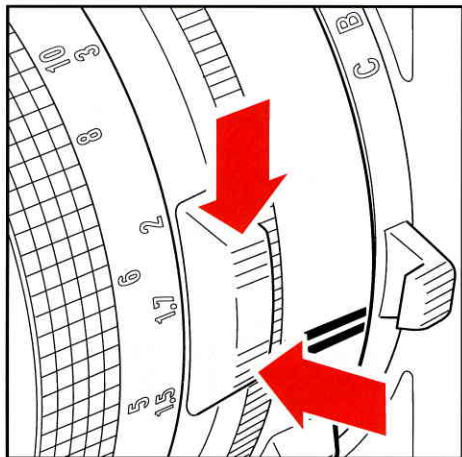

Depth-of-field Preview

The lens is normally set at the largest aperture to provide the brightest possible viewfinder image with the shallowest depth-of-field. You can stop down the lens diaphragm to the pre-set aperture by pushing down the depth-of-field preview knob until it locks. To re-open the diaphragm, depress the lower end of the knob.

Infrared (IR) Photography

Infrared light with wavelengths beyond 800 nm are refracted by the lens to an image plane further away from the lens than the image plane for visible light. When photographing with IR light you have to compensate for this difference by setting the focusing distance at the red IR index to the right of the common index line.

Follow this procedure:

1. Focus as usual on the focusing screen.
2. Mark or memorize the distance on the focusing scale opposite the common index line.
3. Rotate the focusing ring to set this distance opposite the IR index.

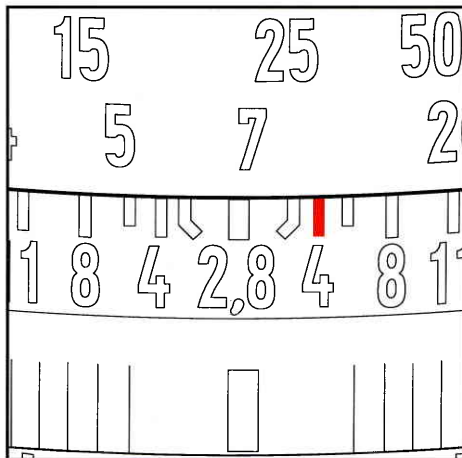

Exposure Value (EV)

The orange scale on the right hand side indicates the exposure value for the set aperture/shutter speed combination. You read the value opposite the orange triangular index on the shutter speed ring. The scale has no particular function on 203FE.

Do not confuse the exposure value with the light value stored in the metering system when you depress and release the AE-lock (page 28).

Other Hasselblad Lenses

How to use other Hasselblad lenses on your 203FE is described on pages 65-66 and in Appendix A.

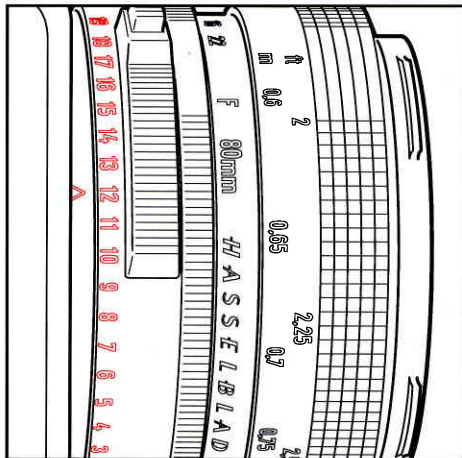

Magazine Operation

Loading the Magazine

You can load the magazine with film on or off the camera. With the magazine slide inserted you have to ensure that its flat side is turned towards the magazine body.

Follow the procedure below to load a film:

(**cw**=clockwise; **ccw**=counter-clockwise)

1. Fold out the film holder key.
2. Turn the key **ccw** and withdraw the film holder.
3. Place an empty take-up spool under the grooved knob of the spool clamp bar. Insert a roll of film under the other end of the bar, turned as in the picture. Remove all of the paper band surrounding the roll!
4. Turn the film holder key **cw** to open the film clamp. Pull 8-10 cm (3-4 in.) of paper backing off the film roll. Slide the side edge under the clamp.
5. Insert the tongue of the backing paper into the slot in the take-up spool.
6. Turn the grooved knob **cw** to align the arrow on the paper with the triangular index on the bar, but no further.
7. Turn the film holder key **ccw**. Insert the film holder into the magazine. Ensure that it is correctly positioned. Turn the film holder key **cw** to lock the film holder in the magazine.
8. Fold out the film winding crank. Rotate it **cw** about ten turns until it stops. Turn it **ccw** and fold it in.

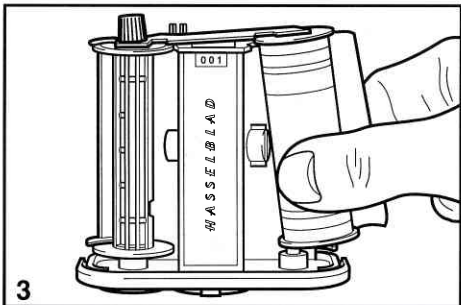
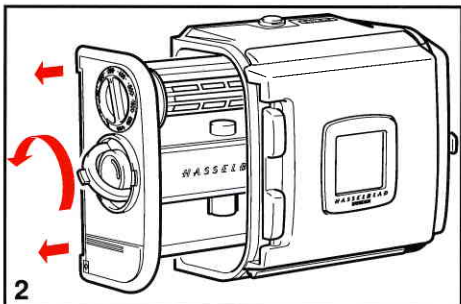
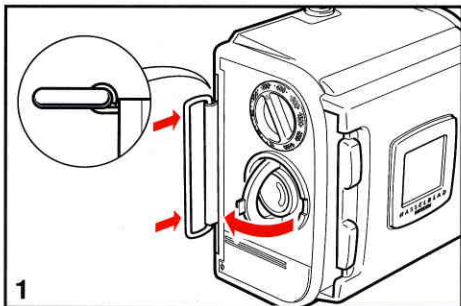

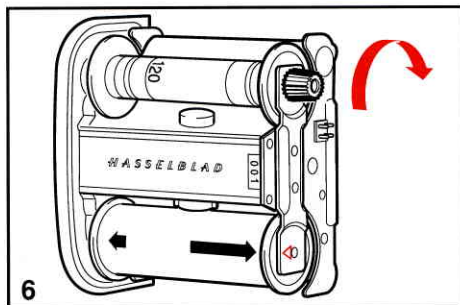
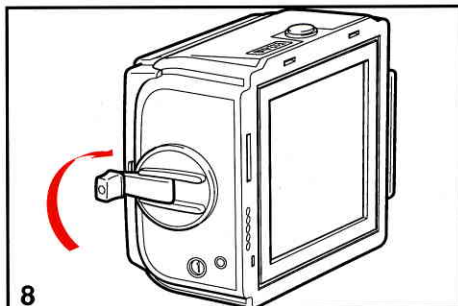
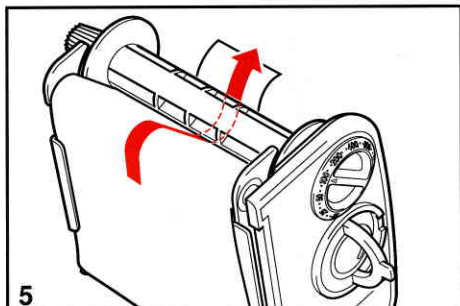
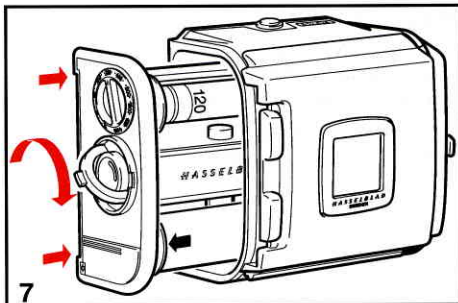
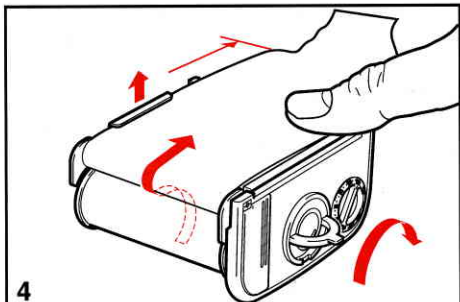

Number 1 will now be displayed in the frame counter window indicating that the loaded magazine is ready for use. The film winding crank is blocked at frame 1 only. It can be used to wind up a partially exposed film at any frame after that. The frame counter is automatically reset when the film holder is withdrawn from the magazine.

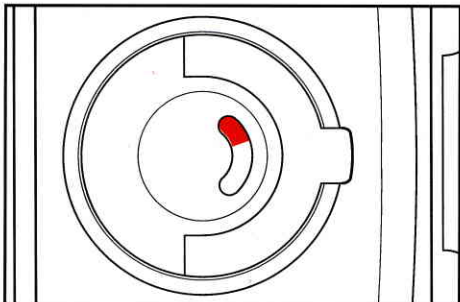

Magazine Load Status

In the center of the film holder key there is a crescent-shaped indicator window that shows white when the magazine is freshly loaded. It gradually changes to red as the film is wound through. An all red indicator shows that the film is used up or that the magazine is empty.

Removing the Film

After the last frame has been exposed and the film advanced, the magazine blocks the camera against further release. To remove the exposed film fold out the film winding crank and rotate it clockwise until you can feel that the film is leaving the supply spool. Withdraw the film holder from the magazine and remove the film.

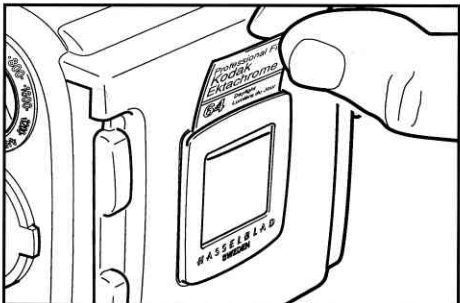

Film Tab Holder

The end tab of the film pack can be inserted in the holder on the back of the magazine as a reminder of the kind of film that has been loaded into the magazine.

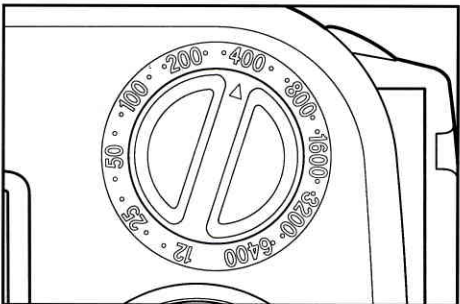

Film Speed Dial

On the left hand side of the magazine above the film holder key is the film speed dial. The speed set on this dial is automatically transferred to the metering system in the camera body and displayed in the viewfinder in the **Pr** mode (page 43). The range of the film speed dial extends from ISO 12 to ISO 6400 with 1/3 and 2/3 intermediate settings.

Magazine Slide Pocket

On the rear of the magazine is the slide pocket where the magazine dark slide could be stowed away when not in use. Turn the slide with the hinge towards the rear to fold the bow fully into the slide pocket recesses.

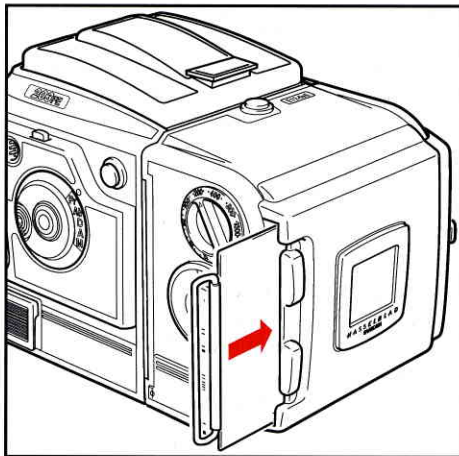

Film Plane Index

Close to the magazine front and moulded into the rubber grip cushion is the film plane index. It can be used to measure the subject-to-film distance when the exact figure is required, e.g. in close-up photography.

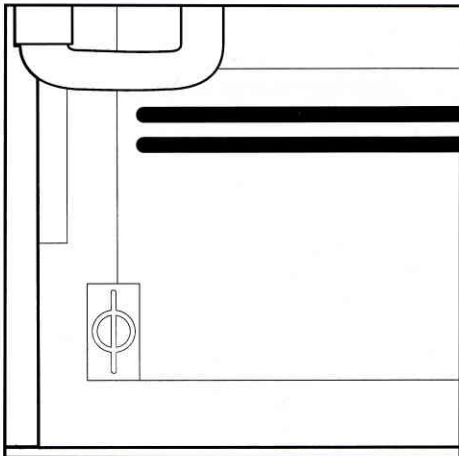

203FE Selective Metering System and Operating Modes

Pages 28 and 29 described in short how you can select the various operating modes of the 203FE. The description included, also in short, the function of the different controls on the control panel and how to use them. The following section describes in detail the metering system and the different operating modes.

The Metering System

The different methods to start the camera and activate the metering system are described on page 16. The system turns off automatically 16 seconds after the last button operation.

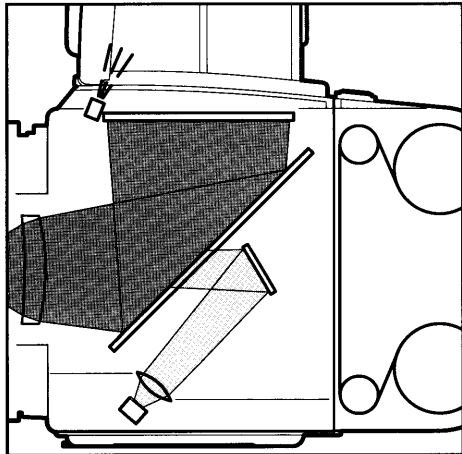

The selective light meter is the most important feature in the metering system. The metering area is indicated by a circle of dots in the center of the focusing screen. The circle has a diameter of 28 mm which is approximately 20% of the total image area.

The meter is very sensitive and accurate. It measures the light reflected from the subject within the metering area, applying a soft integral method, and has a limited reaction to light from outside that area. Thus, even minor displacements of the metering area may result in unexpected changes in exposure values.

NOTE: Like all other reflection exposure meters the selective meter is adjusted to give an exposure value that in the end produces an 18% grey tone, no matter if the metered subject is black, grey, white or of any color. If the metered area is brighter or darker than this 18% grey the metering result has to be adjusted manually up or down to obtain the picture result.

The value that is stored in the metering system is the **light value**. This means that the shutter speed calculated by the system is adjusted automatically if the pre-set aperture or the film speed is changed. The working shutter speed is adjusted in 1/12 at. 1/4 EV-steps (see page 24), i.e. much more accurate than the half speed steps that for practical reasons are used on the viewfinder display.

Other concepts used in this manual are **continuous metering** and **continuous indication**. This means that the system continuously meters the light from the part of the subject which at that very moment lies within the metering area and also continuously updates the value displayed in the viewfinder.

Flashing numbers or symbols in the viewfinder indicate that a warning function has been triggered. See pages 54 and 55 about warnings!

Operating Modes

The different operating modes are described in the order they appear on the Mode Selector Dial.

Pr Programming Mode

The **Pr** mode is not an exposure mode but used to enter certain user defined values, different from the **standard settings**, which are built into the camera. The standard settings are always set when you activate the system after the battery has been removed or if no other values are stored from previous operations. Any change made in the Pr mode is effective until changed again or until the battery is removed.

The Pr mode is not intended for photographing. If you make an exposure with the camera in Pr mode, the camera automatically shifts to **A** mode and then immediately back to **Pr** mode after the exposure.

NOTE: Pre-releasing the camera (page 20) in any of the operating modes always locks the light value that is present at the moment of lifting the mirror.

In the illustrations changing indications are noted with grey symbols and flashing indications by rays around the symbol

NOTE: After a battery change the system always returns to the standard settings and all previously entered values are lost

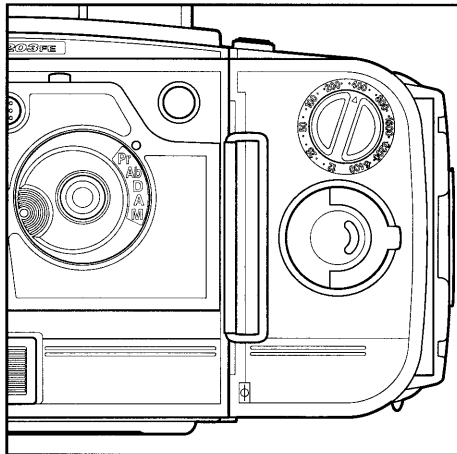

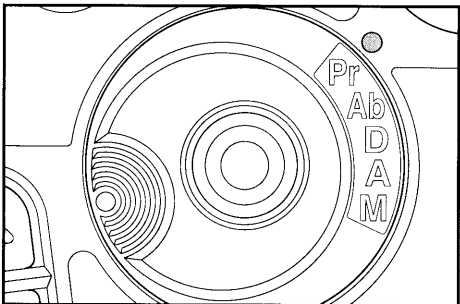
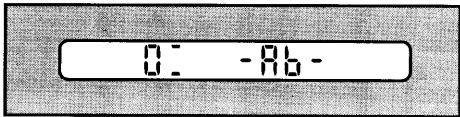
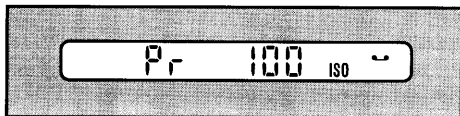

Functions:

Pr1 To set the film speed when you are using standard film magazines. Speed values can be set from 12/12° ISO to 6400/39° ISO in 1/3 EV step (1° ISO) increments.

The standard setting is **100/21°** ISO.

Pr2 To set the selftimer delay in the range from 2 seconds to 60 seconds. The available values are: 2, 4, 6, 8, 10, 12, 14, 16, 20, 30, 40, 50, 60 seconds.

The standard setting is **10** seconds.

Pr3 To adjust the automatic flash metering function, facilitating the use of fill-in flash. The setting range is -3 to +1 EV in 1/3 EV increments.

The standard setting is **0**.

Pr4 To set the exposure shift in the **Ab** mode for automatic bracketing. The shift has four different settings: 0, 1/3, 2/3 and 1 EV.

The standard setting is **2/3 EV**.

Pr5 To switch the reference metering function On/Off and to set the warning levels for reference metering in **M** mode. The standard setting is **Off**.

How to use the "Pr" Mode

The Programming **Pr** mode can be selected whenever the circumstances require a change of the standard values listed above, or a change of previously made settings. The changed values are effective as soon as they are entered.

By repeatedly pressing the AE-lock button you can shift through the Pr-functions in the sequence **Pr1-->Pr2-->Pr3-->Pr4-->Pr5-->Pr1-->**etc. The sequence always starts on the last used function except after a battery change. In **Pr** mode the camera can be started by depressing either the exposure release button to the pressure point or the AE-lock button.

Setting the Film Speed (Pr1 function)

Setting the film speed in Pr mode is possible only when a common A-magazine is used. This is indicated on the display by the symbol "Pr" before the film speed value. With an E-magazine the film speed is set on the magazine dial (page 36), the Pr1 function is inactive and the display shows the magazine dial setting only.

1. Set the Mode Selector Dial in the **Pr** position.
2. Depress the AE-lock button to start the camera and then repeatedly if required to select the Pr1 function.
3. Press the adjustment buttons to change the film speed value. The upper button increases and the lower decreases the value in steps of 1/3 EV.
4. Reset the Mode Selector Dial to the desired exposure mode or press the AE-lock button to switch to next Pr-function.

NOTE: A film speed value manually inserted in the Pr1 function is stored until changed again by the same procedure (or until the battery is removed).

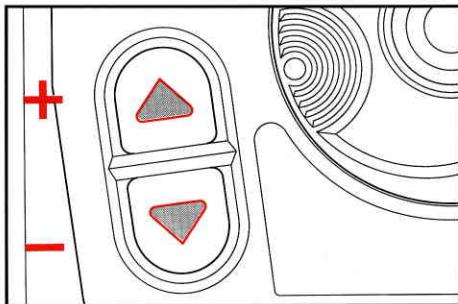
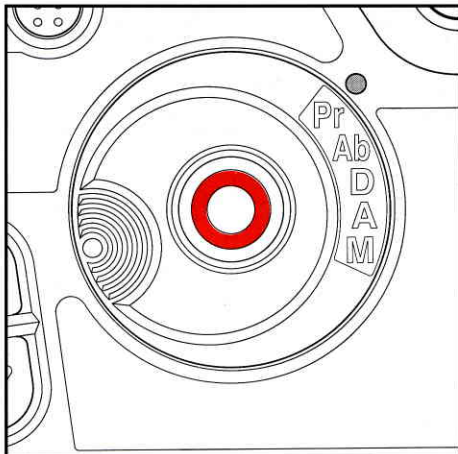

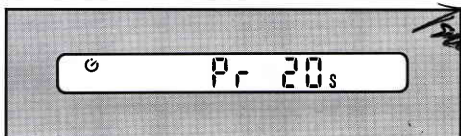
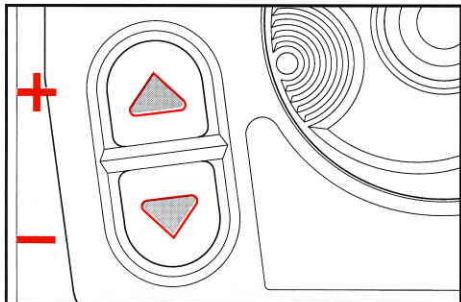
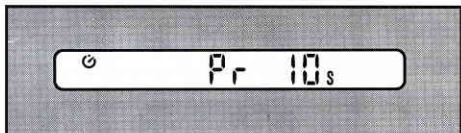
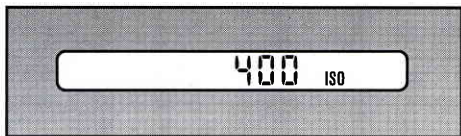

If an E- (or TCC-) magazine is attached the film speed set on the magazine dial overrides the stored value. When the magazine is detached the stored value is automatically recalled. Thus it is easy to shift between E-magazines and common magazines with films of different speeds (e.g. Polaroid films).

Setting the Selftimer Delay (Pr2 function)

1. Set the Mode Selector Dial in the **Pr** position.
2. Depress the AE-lock button to start the camera and then repeatedly if required to select the Pr2 function.
3. Press the adjustment buttons to change the selftimer delay. The upper button increases the delay and the lower button decreases it with the predetermined steps (Pr2, page 40).
4. Reset the Mode Selector Dial to the desired exposure mode or press the AE-lock button to switch to next Pr-function.

Adjusting the Automatic Flash Metering (Pr3 function)

The function is used to introduce a fixed adjustment in the automatic flash control to reduce or increase the flash power, e.g. for fill-in flash applications.

1. Set the Mode Selector Dial in the **Pr** position.

- Depress the AE-lock button to start the camera and then repeatedly if required to select the Pr3 function.
- Press the adjustment buttons to set the desired correction value within the -3 to $+1$ EV range. Pressing the upper button increases the value and pressing the lower button decreases the value.
- Reset the Mode Selector Dial to the desired exposure mode or press the AE-lock button to switch to next Pr-function.

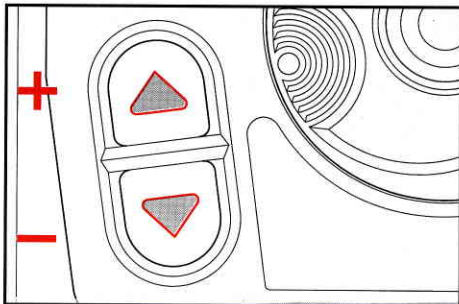

NOTE: If the selected adjustment, combined with the selected film speed, takes the flash metering system outside its operative range (ISO 25 – 1000), the display starts flashing.

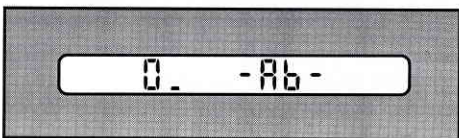

Setting the Automatic Bracketing shift value (Pr4 function)

- Set the Mode Selector Dial in the Pr position.
- Depress the AE-lock button to start the camera and then repeatedly if required to select the Pr4 function.
- Press the adjustment buttons to change the exposure shift. Pressing the upper button increases the value and pressing the lower button decreases the value. The indicated step value is a \pm value (page 44).
- Reset the Mode Selector Dial to the desired exposure mode or press the AE-lock button to switch to next Pr-function.

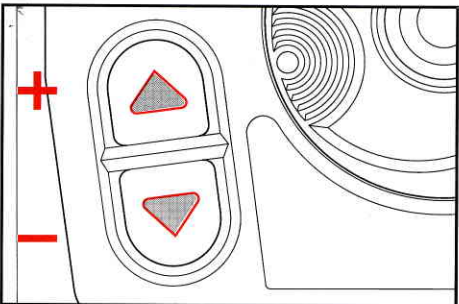

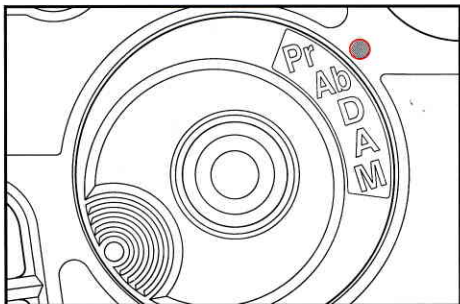
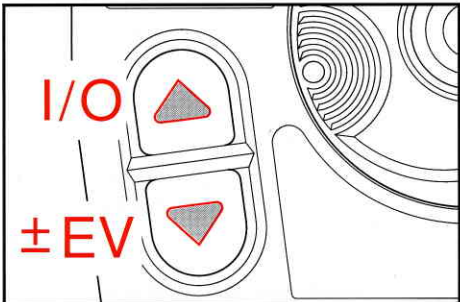
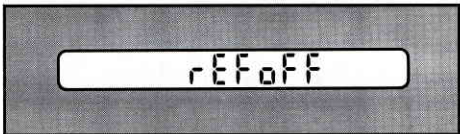

Operating the Reference Metering (Pr 5 function)

In Pr mode the reference metering function can be switched on or off and the warning levels can be established.

1. Set the Mode Selector Dial in the **Pr** position.
2. Depress the AE-lock button to start the camera and then repeatedly if required to select the Pr5 function.
3. Use the upper adjustment button as a toggle switch to switch the function on or off.
4. Press the lower adjustment button to set the desired warning levels with 1/3 EV increments within the 1/3 to 3 EV range. The value is a \pm value, symmetrical with the 0 level. Setting 0 disables the warning function.
5. Reset the Mode Selector Dial to the desired exposure mode or press the AE-lock button to switch to next Pr-function.

Ab Automatic Bracketing Mode

Function:

Automatic exposure with aperture priority, pre-selected film speed and automatically calculated shutter speed.

Exposure bracketing with 0, 1/3, 2/3 or 1 EV-step preselected bracket increments.

Features:

Continuous metering of the light value.

Locking and storing of the light value at a selected moment by keeping the exposure

button at the pressure point.

Permanent preselected adjustment of the continuous or stored light value ± 5 EV-steps in $1/3$ EV-step increments.

How to Use the "Ab" Mode

For the best utilization of the sequential Ab mode you are recommended to use the Hasselblad winder accessory.

The selective meter in the 203FE is very sensitive and reacts to the smallest change in the light level within the metering area (pages 13 and 38). The shielding of the sensor makes it much less sensitive to light outside that area. The metering area should be located on a suitable subject part and the changing readings in the viewfinder display carefully observed before storing the reading or releasing the exposure.

Exposure bracketing is very useful when the subject is difficult to meter or when the possibility to make an accurate determination of the exposure value is limited. Bracketing is best performed by using of the winder for the smoothest operation.

The camera runs as long as the exposure button is kept depressed or until the film is finished, and for each exposure after the first one the shutter speed is changed according to the preset shift step value. The second frame gets one step more exposure (lower EV); the third one step less (higher EV); the fourth two steps more; the fifth two steps less; and so on.

The bracketing shift function is limited to 10 exposures above and below of the originally

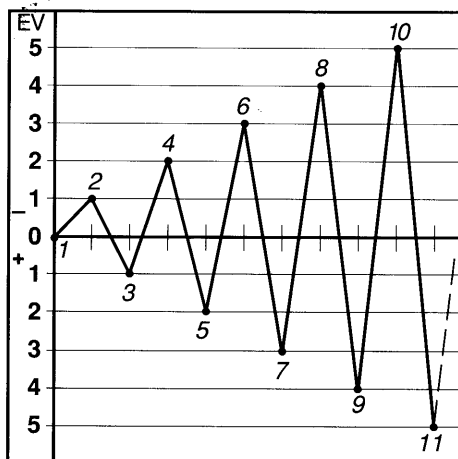
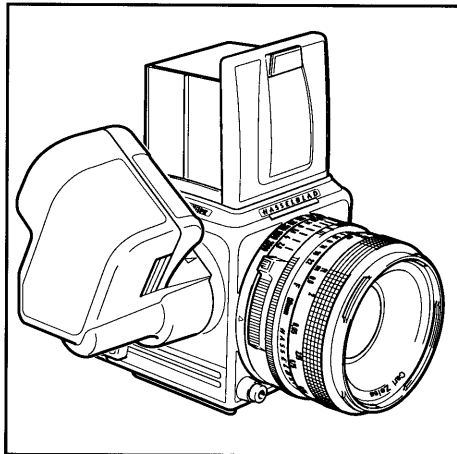

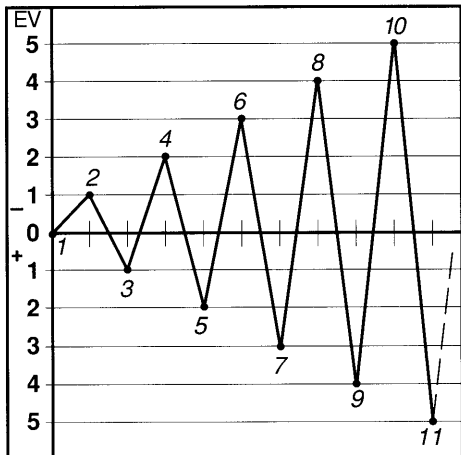

metered and stored light value. Thus, after 21 exposures there is no more shift in the exposure values. During the bracketing operation the light meter is disabled.

The value of the shift step should be preset to any of the steps 0, 1/3, 2/3 or 1 EV in Pr mode (page 43). Default value is 2/3 EV, which gives a total exposure span of 6 2/3 EV. With a shift step of 1 EV the max. total span is as large as 10 EV. If any of the shutter speed limits (90 s or 1/2000 s) is reached during bracketing that speed will be repeated until the operation is terminated.

For an exposure sequence without any bracketing shift the zero step should be selected, but in that case the “A” mode is recommended.

Suggested procedure:

1. Pre-set the desired bracketing shift value using the Pr4 function (pages 40, 43)
2. Pre-set the film speed. With an E- (or TCC-) magazine, set the film speed dial (page 36). With a standard magazine use the Pr1 mode to enter and store the film speed (page 41). Pre-set the desired aperture.
3. Set the Mode Selector Dial at **Ab** and aim the camera to locate the metering area on a selected subject part.
4. Start the metering system by depressing the exposure release button (page 23) to the “pressure point”. The display shows the pre-set aperture, the letter “L” to indicate that the displayed shutter speed (calculated from that aperture, the pre-set ISO

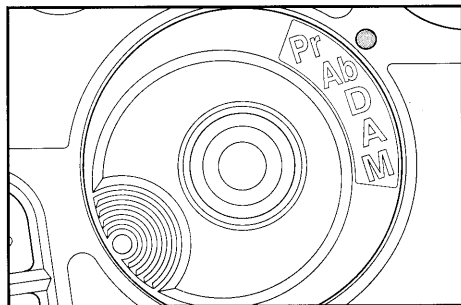

value and the metered light level) is locked in the metering system, and an "A" for Automatic Mode. When you release the button the aperture figures are replaced by a figure, that shows the stored exposure correction. The system changes to the continuous metering state and the shutter speed figures keep changing when the metering area is moved about. If the display goes out, the system is re-activated by depressing the exposure button half-way again.

Depressing the exposure button fully at this stage releases an exposure with the shutter speed that was locked and stored when the exposure button reached the pressure point on the way in.

NOTE: The system can also be started by depressing the AE-lock button. It then reacts as described in p.5 below.

Depressing the AE-lock button erases all previously stored exposure information.

5. Depress and release the AE-lock button to **lock and store** the exposure of a selected subject area. The display shows the stored shutter speed, "L" for locked and "0" for "no adjustment". If the aperture or ISO setting is changed the shutter speed adjusts automatically.

NOTE: Depressing the exposure button re-sets the system to p.4 above.

6. Use the adjustment buttons (page 29) to adjust the stored exposure if necessary. The display shows the + or – amount of

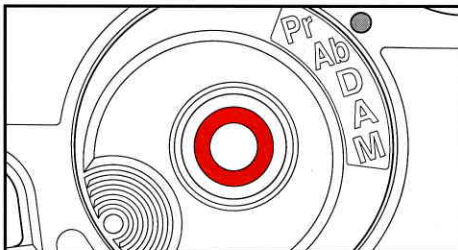
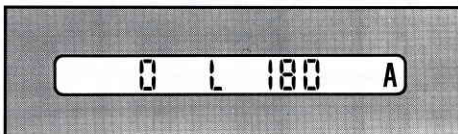
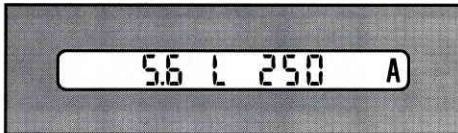
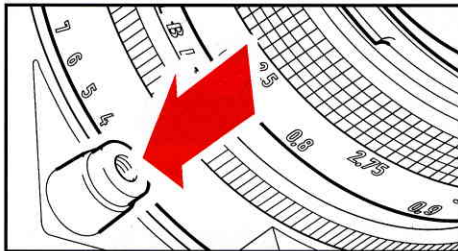

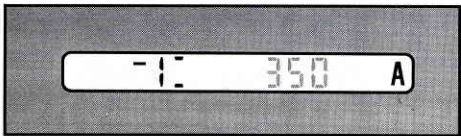
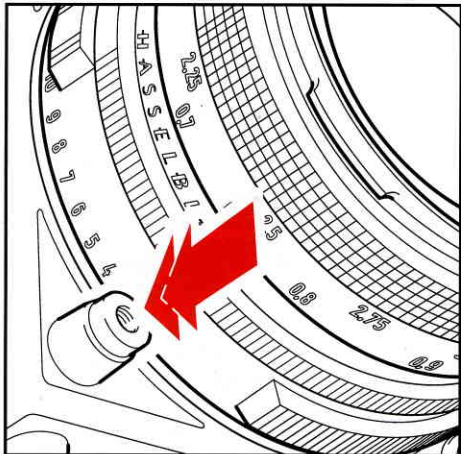
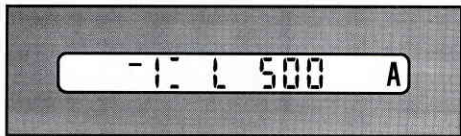

adjustment in 1/3 EV-step increments (page 19). The adjusted shutter speed is shown with 1/2 speed-step increments although the shutter speed is actually adjusted in 1/3 steps.

NOTE: “+” adjustment **decreases** and “-” adjustment **increases** the shutter speed. Any adjustment made with the adjustment buttons remains stored after exposure release until next time the AE-lock button is depressed.

7. Depress the exposure button fully to make an exposure according to the stored (and corrected) values.
8. Keep the exposure button depressed to make a sequence of exposures with the shutter speeds changing according to the preselected bracketing steps. The original exposure data remain on the display and the metering system is deactivated until the exposure button is released and the camera rewound after the last exposure. When the exposure button is released the metering system is then reset to continuous metering with the latest adjustment parameters.